

Choose
the future

Choose

BRAUMS

Roadway Lighting



**BRAUMS PX SERIES
P CATEGORY
LED STREET LIGHTS**

Higher reliability

Higher efficiency

Lower power consumption

Easier and Safer installation

BRAUMS PX SERIES P CATEGORY LED STREET LIGHTS

P-Street LED is based on an extremely high-power and high-efficiency LED module and reliable, constant-current LED driver, which guarantees the most appropriate power consumption and lumen density along with longer lifetime at higher operating temperature.

This new, innovative product targets Australia's Pedestrian Area and Minor Road (Category P) and complies with the requirements of AS/NZS 1158.

P-Street LED features high performance and reliable LEDs, Flat Aero Screen Visor OR Cutaway Visor, IP66 Optical Chamber, IP24 Electrical Chamber and convenient installation to the customer, significantly reducing maintenance costs.

Access to the electronic control equipment is by opening the back shelf on the top via quick release latches, which allows easy installation. NEMA circuit installed and NEMA base capable for 3, 5 or 7 PINs.

Onboard and outboard Smart Lighting control interfaces also available with plug'n'play 7 Pin NEMA module compatible with popular IoT networks including; LoRa WAN, Sigfox and NB-IoT.

Features

- Correlated Colour Temperature (CCT): 4000K
- Colour Rendering Index: ≥ 70
- Flat Aero Screen Visor or Cutaway Visor
- Low power consumption P1-P5 16W
- Dimming capable
- NEMA switch on device with auto turn on when removed
- IoT smart controls

- Tool-less top entry
- Cloud hosted applications

Key Applications

- Minor roadway
- Security lighting
- Cycle pathways
- Pedestrian
- Car park
- Amenity

Electrical Performance

- Input Voltage: 240VAC
- Frequency: 50Hz
- Power consumption: P1-P5 16W
- Power Factor: > 0.95
- 1-10VDC Dimming System
- Operating temperature: $+40^{\circ}\text{C}$

Mechanical Features

- Polyester powder-coated pressure diecast aluminium housing and shell
- Clear polycarbonate Flat Aero Screen or Cutaway Visor
- Convenient clips
- Weight: 6.1 Kg
- Mounting angle: $-5^{\circ} / 0^{\circ} / +5^{\circ} / +10^{\circ}$
- Mounting height: 5.5 m, 6.5 m, 7.5 m
- Dimension: 453mm x 281mm x 154mm
- Optional rotating spigot to allow luminaire to flip 180° for easy replacement of LED module. Refer to Fig. 1 and Fig. 2



Fig 1.

Optional rotating
spigot fitted



Fig 2.

Optional rotating spigot fitted

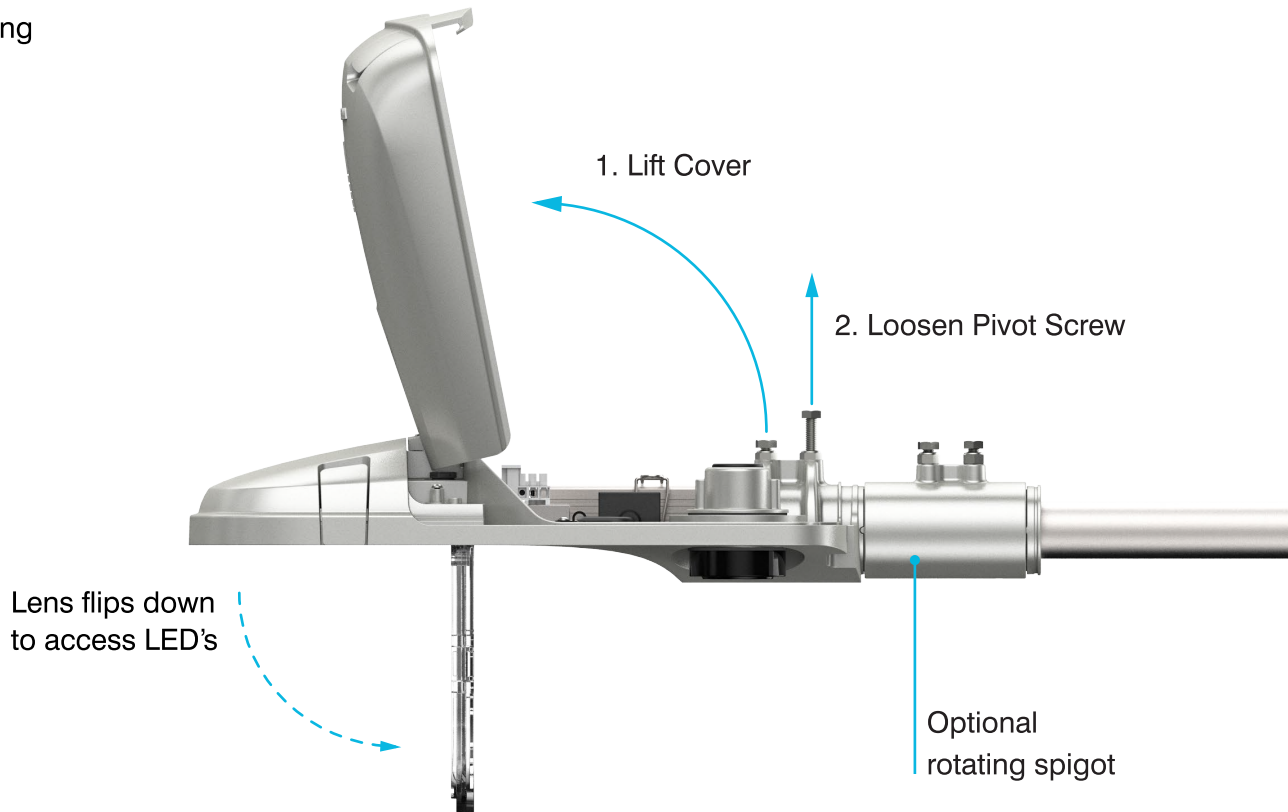

Luminaire Flipped 180°

With optional rotating spigot installed, the PX can be rotated 180° to enable access to all components from either above or below the luminaire as per specified work practices.

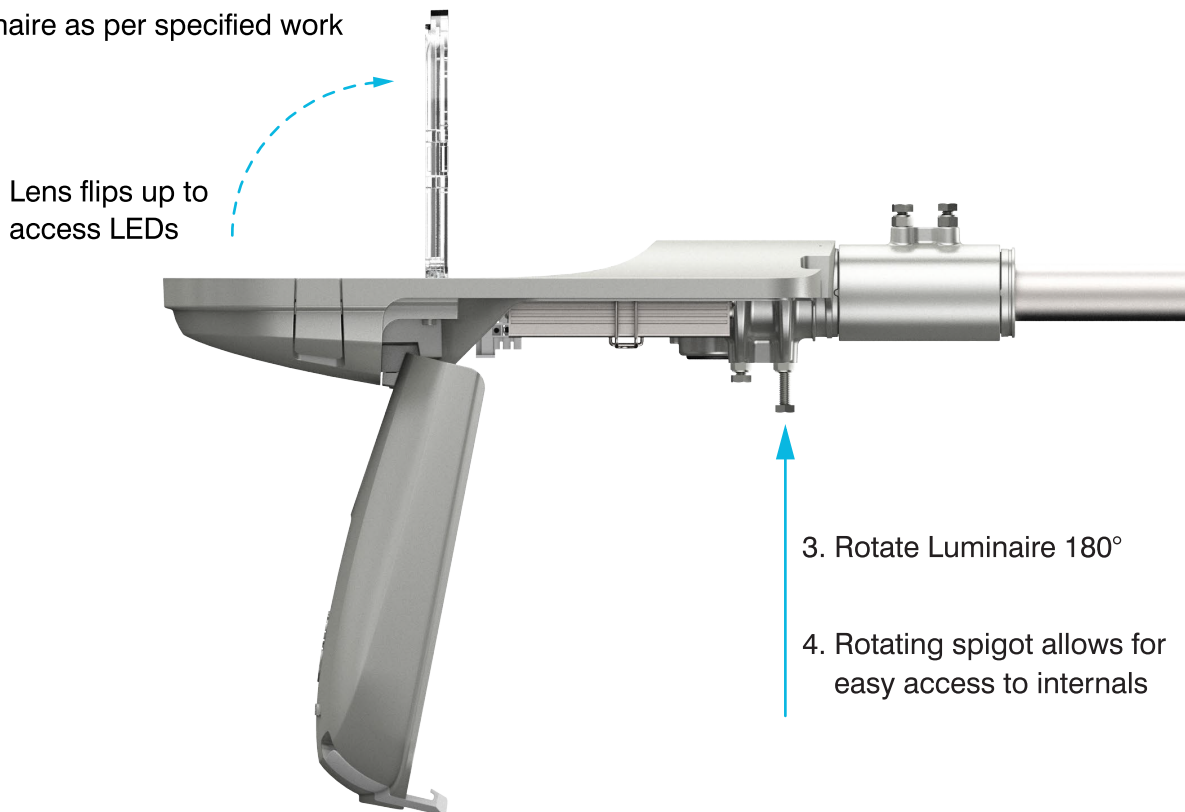

P CATEGORY LED STREET LIGHTS

Dimensions

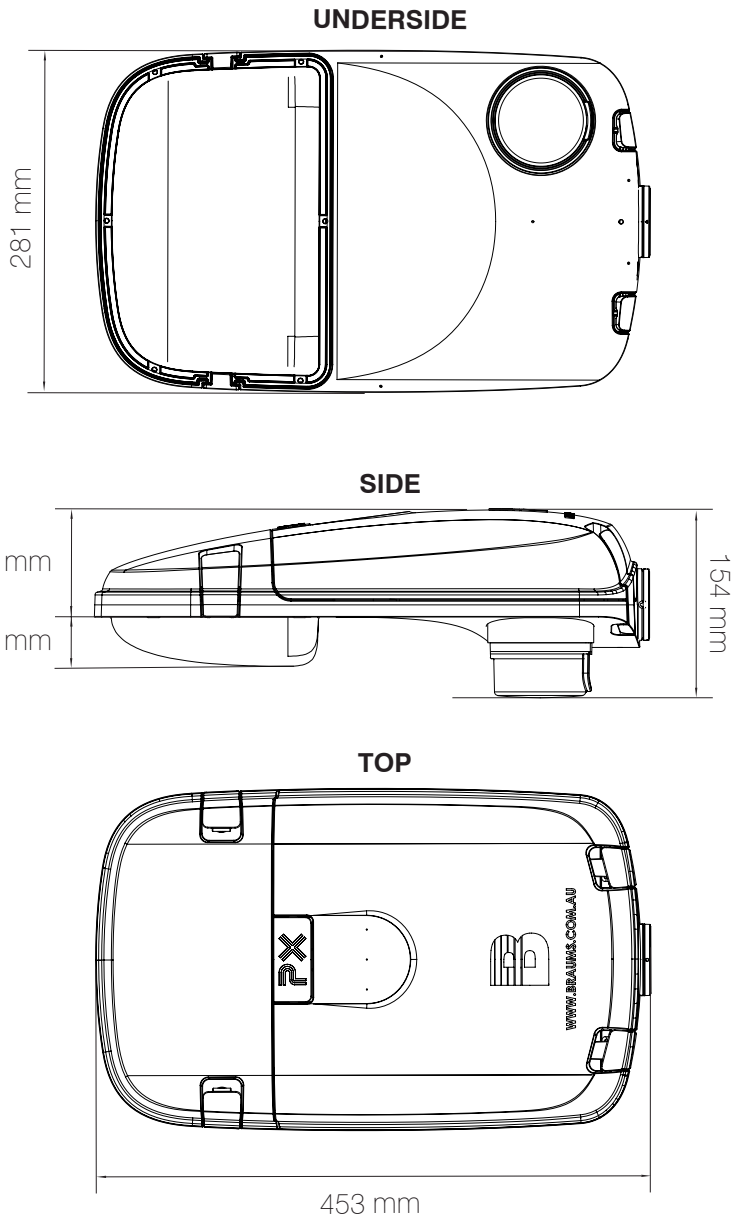

BRAUMS Pty Ltd
 Telephone: +61 2 9684 3300
 Facsimile: +61 2 9684 3390
 E-mail: info@braums.com.au
 Unit M, 10-16 South Street,
 Rydalmere NSW 2116 Australia
 PO Box 324 Ermington NSW 2115

ABN 31 150 551 732
www.braums.com.au